



MapleTree Audio Design  
100 Cliff Cres  
Kingston, ON  
CANADA K7M 1A8

al@mapletreeaudio.com  
www.mapletreeaudio.com

## Notice

**Power supply unit should be plugged into the amplifier unit with the tubes in the correct sockets BEFORE POWERING UP.**

**Please allow at least 12 hours for the tubes to burn in since they are new. It is not uncommon to hear crackling and metal expanding for new tubes.**

**Stacking amplifier on top of the power supply will increased hum. A magnetic shielding plate, 1/8" to 1/4 " "steel plate", with acoustic dampening, felt/rubber, can be used between the amplifier and power supply to reduce the hum. Adding additional pates reduces hum further. If this is still an issue separate the power supply unit from the amplifier unit.**

**Do not clean with alcohol or paint thinner. A soft 1 inch paintbrush is recommended to dust the chassis periodically.**

**Read Manual before operation.**



## ***Line 2CRM Stereo Line Preamp*** ***PS 2D Power Supply***

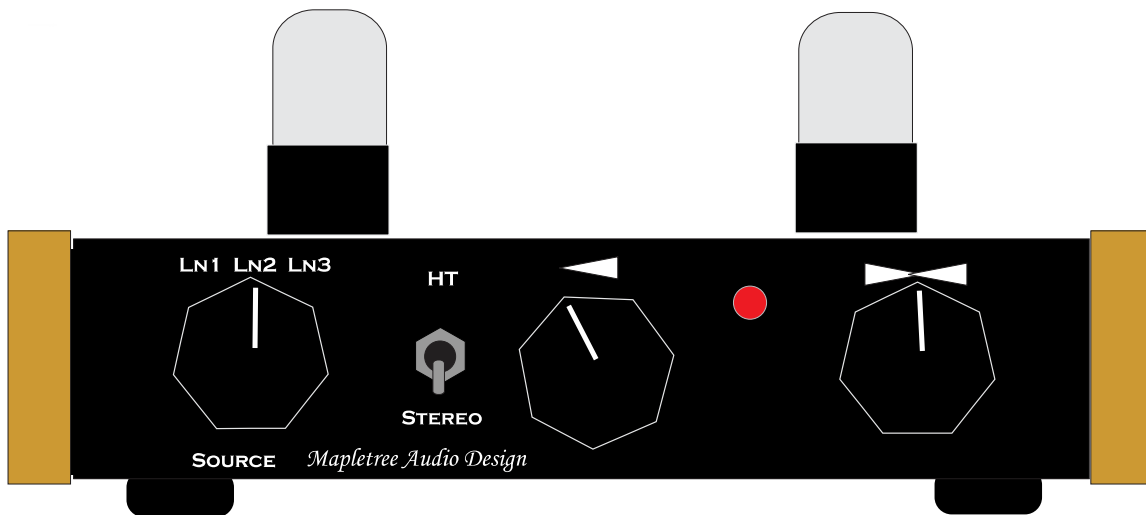

## **User's Manual**

Rev. Dec 5, 2023

Mapletree Audio Design  
100 Cliff Cres., Kingston, ON, CANADA K7M 1A8

[www.mapletreeaudio.com](http://www.mapletreeaudio.com)  
[info@mapletreeaudio.com](mailto:info@mapletreeaudio.com)

© Copyright L. Peppard/A. Freundorfer 2002-2023      -Specifications are subject to change without notice-

## **Introduction**

The Mapletree Audio Design *Line 2CRM Stereo Line Preamplifier* offers the audiophile a number of desirable features:

- Remote volume control with handset.
- Bypass switch on front panel for home theatre (HT) operation.
- Exclusive use of NOS octal tubes, known for low distortion and musicality.
- Switchable for use with 12SN7GT or 6SN7GTB tubes.
- High input impedance and low output impedance.
- Parallel output jacks for bi-amp/headphone amp/HT applications.
- Audio grade polypropylene film capacitors in signal path.

## Power Supply Connections

The Mapletree Audio Design *PS 2D* power supply provides +12 VDC (regulated) heater supply voltage and +200 VDC B+ plate supply voltage at a current of 15 mA (see specifications). It utilizes ultra high-speed diode bridge rectification to achieve low noise and high efficiency.

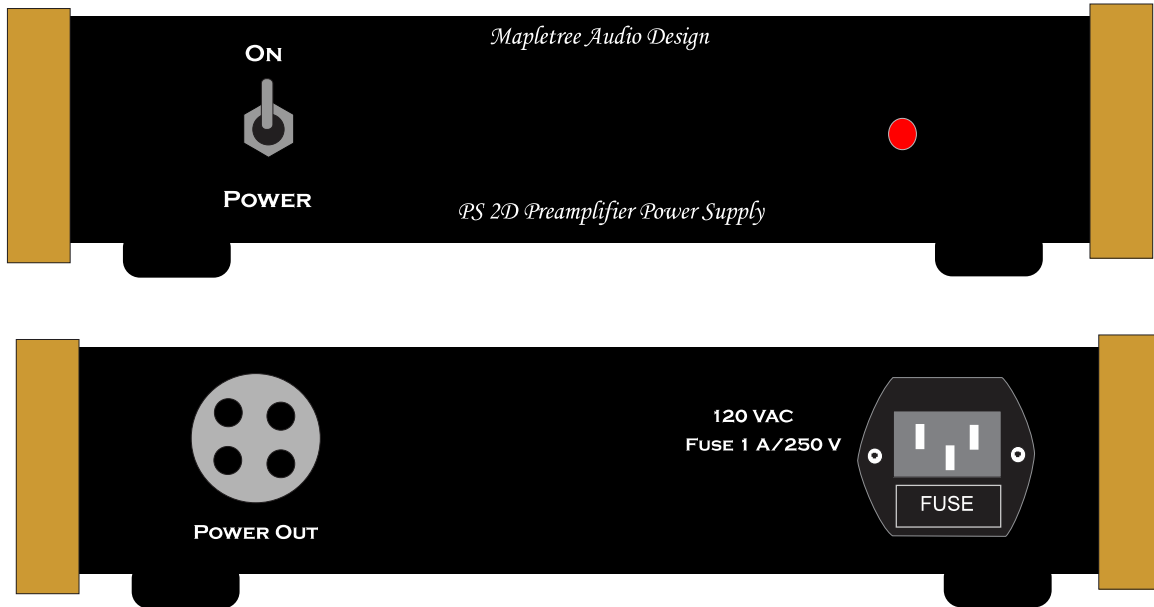

The separate power supply eliminates induced hum originating from power supply circuitry and components. The power connections to the preamplifier chassis are made through a special 3-conductor power cord that plugs into jacks located on the rear panels of the power supply and preamplifier chassis.

**CAUTION: Do not operate the power supply when it is not connected to the preamp. Damage of components may result.**

Once the interconnecting power cord is securely attached between the two chassis and the line cord is plugged in, the power supply can be turned on. The pilot lamp on the power supply chassis indicates that the unit is on. It takes about 30 seconds for the tubes to reach operating temperature ready for use. During operation, it is normal for the power supply chassis to become warm to the touch.

The power supply is protected by a 20mm, 1 A/250 V fast-acting fuse, which can be accessed by removing the fuse drawer from the ac inlet receptacle after the unit has been unplugged for at least 60 sec. Under normal conditions, it should not be necessary to

replace the fuse. If the fuse blows, you should not try to operate the unit. Contact Mapletree Audio Design for information

### **Signal I/O Connections**\_\_\_\_\_

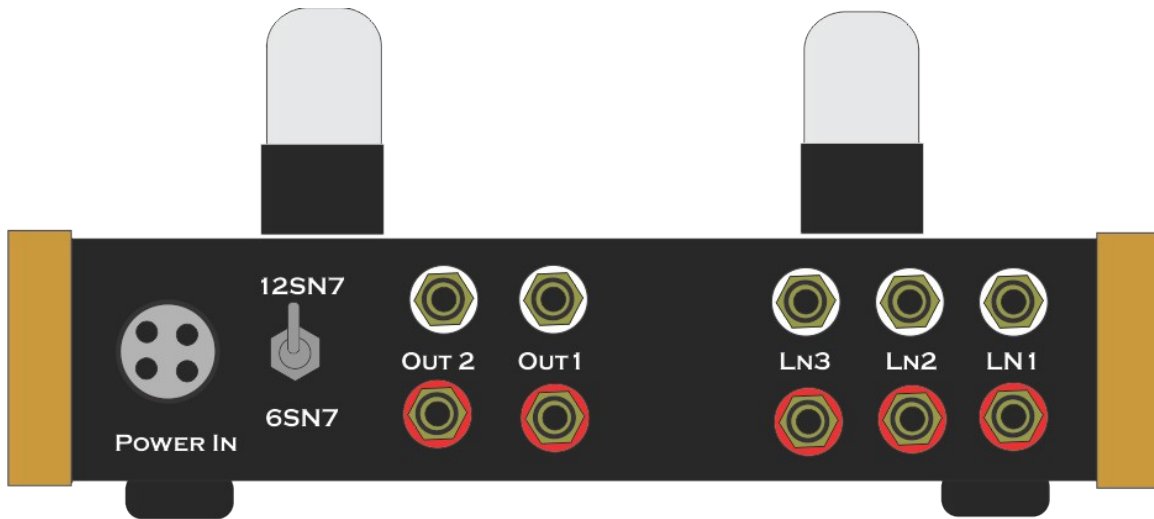

The signal input/output jacks are located on the rear panel of the preamplifier chassis. RCA jacks are provided for three line inputs and two line outputs. The outputs can be used for bi-amp operation, connection to a headphone amp, or to the front channel inputs to a home theatre (HT) system. Left channel jacks are at the top and right channel jacks are at the bottom. The line input impedance is 100k $\Omega$  with standard 10 dB gain which provides minimal loading of any line source such as DAC, CD/DVD player, tape deck, tuner, or PC sound card. The output impedance is less than 500 $\Omega$  which is suitable for connection to a power amplifier(s) through cables up to 10 ft in length.

The heater voltage switch located next to the power input jack accommodates either 12SN7GT (supplied) or 6SN7GTB tubes in your *Line 2C*. ***While it will do no damage to switch to 6SN7 position with 12SN7 tubes installed, operation in the 12SN7 position with 6SN7 tubes may damage the tubes.***

## **Front Panel Controls**

The front panel controls are (left to right) the 3-position Source selector switch (Line1-Line2-Line3), Mode switch (Stereo or HT), Volume control, and Balance control. In HT mode, the selected input source is connected to the output jacks and the active preamp output is disabled; the power may be turned off.

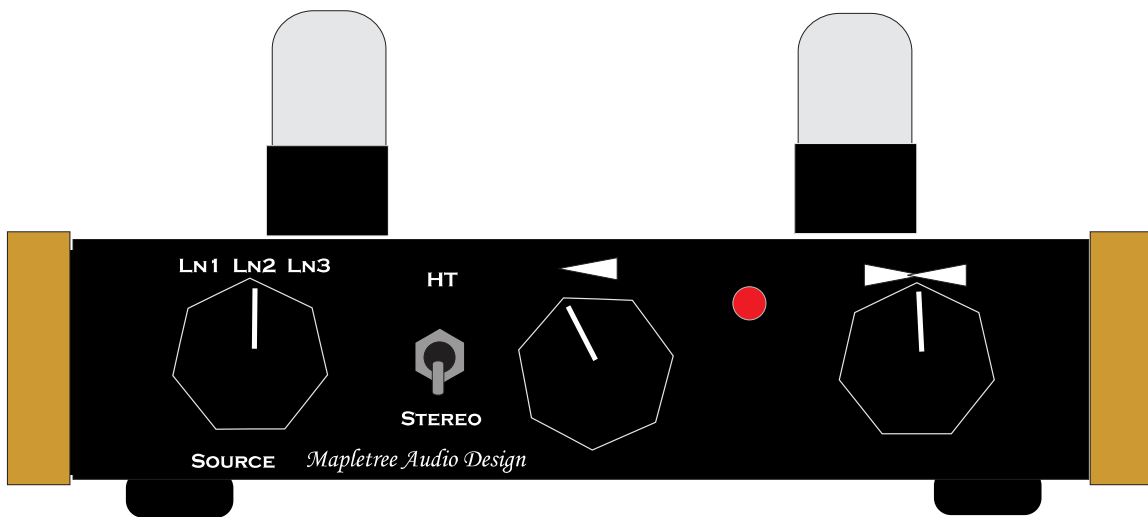

## **Remote Volume Control**



The volume control IR sensor is located between the volume and balance control as shown above. The remote handset has buttons for volume up and down. The “OFF/ON” button mutes the preamp.

## **Tubes**

The tubes supplied are new-old stock (NOS) and have been pre-tested. A burn-in period of several hours may be needed to achieve the best sonic performance. Tube life should be thousands of hours. Aging tubes may result in a reduced gain in one or both channels or an increase in noise levels. Infrequently, a heater may burn out which is indicated by total loss of sound. Replacement tubes can be obtained from several suppliers in the U.S. and Canada. Some listeners enjoy trying different brands and variants of tubes. The heater voltage selector switch permits the use of 6SN7GTB (or the 5692 special red version) tubes of NOS or current manufacture. The highly regarded 12SX7GT is equivalent to the 12SN7GT.

## **Care of Your Line 2**

The chassis finish is lacquer-based and, while hard (and continues to harden over time), is subject to chipping on impact with another object. Both the chassis and labels/logos are moisture resistant but you should avoid cleaning with water, alcohol, or other strong chemical. A soft 1" paintbrush is recommended to dust the chassis periodically.

Heat is the most troublesome enemy of electronic components, especially capacitors. Heat can be properly dissipated by ensuring free air circulation around the preamp and power supply chassis. It is not recommended that you leave the power on when not in use.

## **Warranty**

Assembled components are warranted for 2 years to the original purchaser for failure of parts (excluding tubes) and workmanship. Tubes are warranted for 90 days exclusive of shipping cost. Service, including parts and labor (but excluding shipping), is free within the warranty period.

## **Line 2CRM Specifications**

**Frequency response (1 V output, 100K load):** 20 Hz–20 kHz –0.3 dB (any volume control setting)

**Max. output voltage (100K $\Omega$  load):** 15 V

**Gain:** 10 dB (standard—can be ordered with input gains of 0 dB to 20 dB)

**Channel balance:**  $\pm 0.2$  dB

**Balance control:** 3 dB channel shift at 9 and 3 o'clock position with vol. control at 12 o'clock

**Hum and noise:** less than 1 mV at full gain, no input

**Input impedance (1 kHz):** 100 k $\Omega$  (with standard 10 dB gain)

**Output impedance (1 kHz):** 450  $\Omega$

## **Power Supply (PS 2D)**

**Power output:** +12 VDC @ 1A, +180-250 VDC @ 14 mA (ground is common to both).

**Fuse:** 1 A, 250 V fast action

**Power consumption:** 30 W, 120 VAC, 50-60 Hz

# Mapletree Audio Design Line 2C RM Stereo Line Preamplifier

with remote volume control and home theatre feed-thru

Rev. Nov 25, 2019

© Copyright Lloyd Peppard 2002-2019

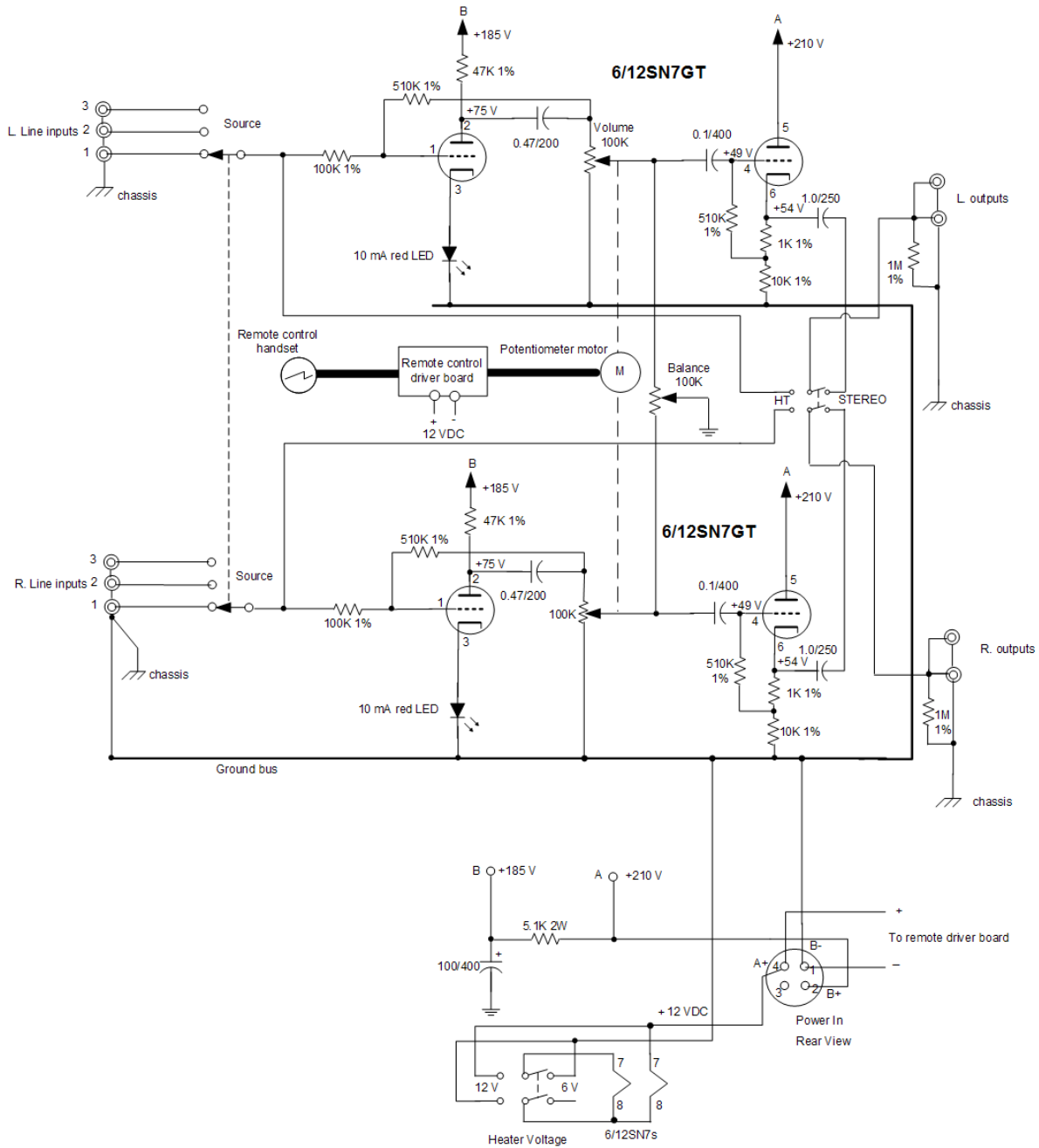



# Mapletree Audio Design Preamplifier Power Supply PS 2D

© Copyright Lloyd Peppard 2018-19

Rev. June 3/18

